

T 型

37° Flare Tube Fittings

構造と特性

1. 構造

- A) T型は本体①、スリーブ②、袋ナット③の三点セットで構成され、本体のフレア面は37°の外ネジ式です。
- B) 接続は袋ナット③、スリーブ②をパイプに挿入後ツールでパイプを37°にフレアし袋ナット③を締付け接続させます。
- C) 本体①、袋ナット③のストレートネジ部はISO規格UNF(ユニファイ)ネジで、本体①のテーパネジ部はISO規格R.RcネジまたはANSI規格NPTネジです。
- D) 本体①のテーパネジ部が平行ネジの場合はISO規格Gによります。

2. 特性

- A) 袋ナット③を締付の際、スリーブ②は回転せずフレア面が均等に締付けられます。
- B) フレアの接触面に回転摩擦がない為、フレア箇所を損傷する事はありません。従って取り外しの激しい箇所に最適です。
- C) 最高使用圧力は4.9MPa(50kg/cm²)常温。

3. 御注文によりSUSにても製作致します。

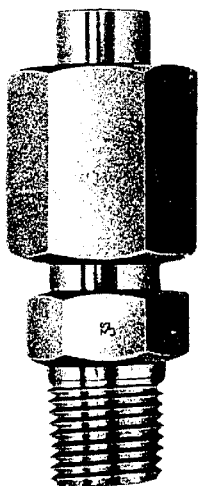
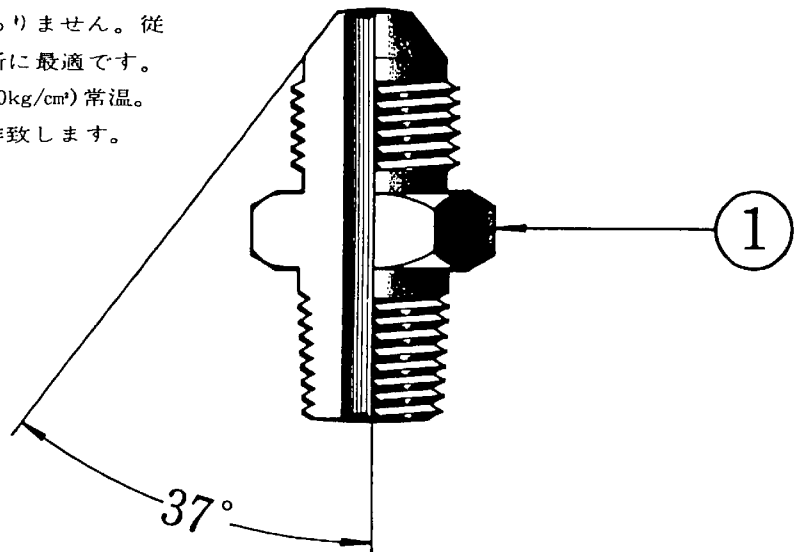
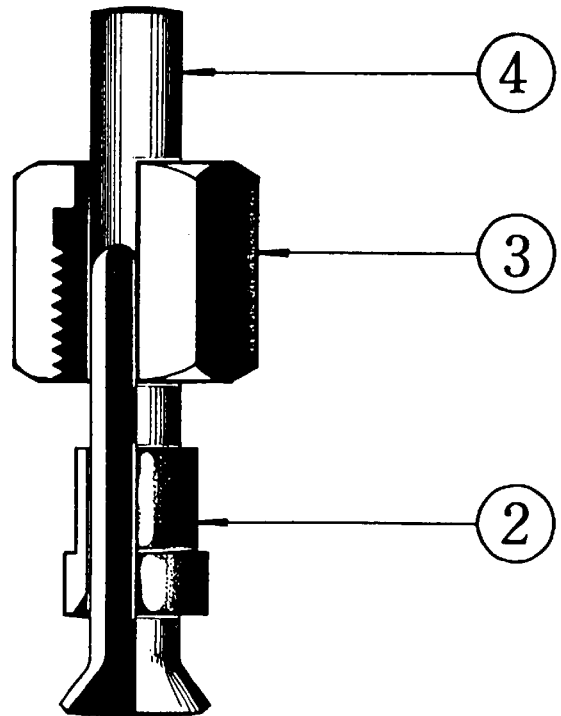

品番	部品名称	標準材料
1	T型ボディー	C3604
2	T型スリーブ	C3602
3	T型フクロナット	C3604
4	使用銅管	C1220

ST-TYPE

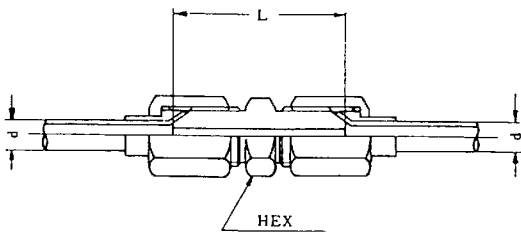
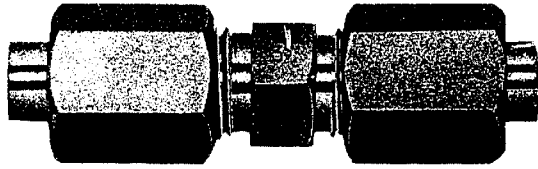

単位/mm
Dimension in mm

型式 Type	使用銅管外径 Tube O.D	L	対辺 Opposite side
	d		HEX
ST 6	6	29	12
ST 8	8	34	17
ST 10	10		
ST 12	12	39	21
ST 15	15	41	23
ST 16	16	50	26
ST 18	18		29
ST 20	20		
ST 22	22	51	32
ST 25	25		35
ST ¼	6.35 (¼")	29	12
ST ⅜	9.52 (⅜")	34	17
ST ½	12.7 (½")	39	21
ST ¾	19.05 (¾")	50	29
ST 1	25.4 (1")	51	35

WST-TYPE

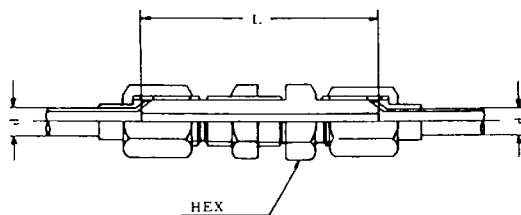
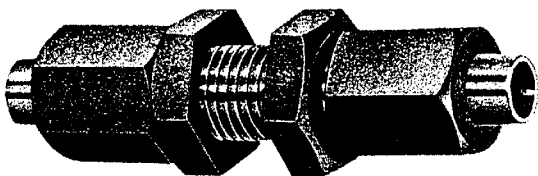

単位/mm
Dimension in mm

型式 Type	使用銅管外径 Tube O.D	L	対辺 Opposite side	穴明 寸法 Bore diameters
	d		HEX	
WST 6	6	42	17	12
WST 8	8	49	21	15
WST 10	10		23	16
WST 12	12	55	26	20
WST 15	15	57	29	23
WST 16	16	67	32	26
WST 18	18		38	29
WST 20	20			
WST 22	22	70	41	32
WST 25	25		46	36
WST ¼	6.35 (¼")	42	17	12
WST ⅜	9.52 (⅜")	49	23	16
WST ½	12.7 (½")	55	26	20
WST ¾	19.05 (¾")	67	38	29
WST 1	25.4 (1")	70	46	36

単位/mm
Dimension in mm

SMT-TYPE

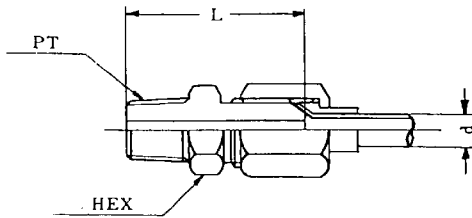
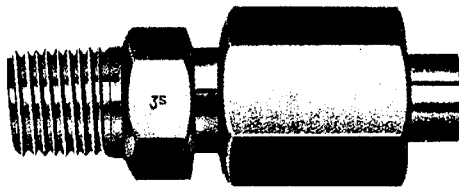

型式 Type	使用銅管外径 Tube O.D d	管用ネジ Pipe thread		L	対辺 Opposite side HEX
		PT			
SMT 6 × 1/8	6	1/8	R NPT	27	12
SMT 6 × 1/4		1/4		30	14
SMT 6 × 3/8		3/8		32	19
SMT 6 × 1/2		1/2		37	23
SMT 8 × 1/8	8	1/8	R NPT	30	17
SMT 8 × 1/4		1/4		33	
SMT 8 × 3/8		3/8		34	19
SMT 8 × 1/2		1/2		39	23
SMT 10 × 1/8	10	1/8	R NPT	30	17
SMT 10 × 1/4		1/4		33	
SMT 10 × 3/8		3/8		34	19
SMT 10 × 1/2		1/2		39	23
SMT 12 × 1/4	12	1/4	R NPT	36	21
SMT 12 × 3/8		3/8		37	
SMT 12 × 1/2		1/2		41	23
SMT 16 × 1/2	16	1/2	R NPT	47	26
SMT 18 × 1/2	18	1/2	R NPT	47	29
SMT 18 × 3/4		3/4		49	
SMT 1/4 × 1/8	6.35 (1/4")	1/8	R NPT	27	12
SMT 1/4 × 1/4		1/4		30	14
SMT 1/4 × 3/8		3/8		32	19
SMT 1/4 × 1/2		1/2		37	23
SMT 3/8 × 1/8	9.52 (3/8")	1/8	R NPT	30	17
SMT 3/8 × 1/4		1/4		33	
SMT 3/8 × 3/8		3/8		34	19
SMT 3/8 × 1/2		1/2		39	23
SMT 1/2 × 1/4	12.7 (1/2")	1/4	R NPT	36	21
SMT 1/2 × 3/8		3/8		37	
SMT 1/2 × 1/2		1/2		41	23

SNT-TYPE

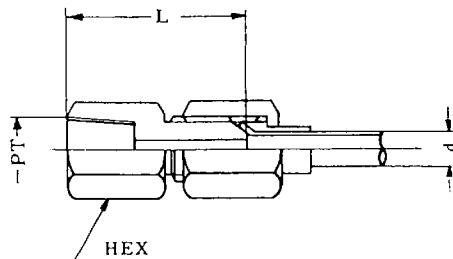
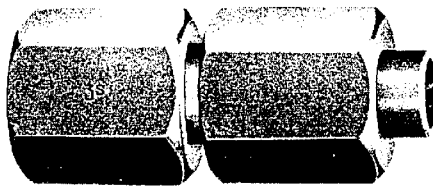

※PT部をG(平行ネジ)でも製作します。

(パッキンは皮パッキン)

* It is possible to fabricate for "G" (Parallel Pipe Thread) instead of "PT".

(The Packing is leather made)

単位/mm
Dimension in mm

型式 Type	使用銅管外径 Tube O.D d	管用ネジ Pipe thread		L	対辺 Opposite side HEX
		PT			
SNT 6 × 1/8	6	1/8	Rc NPT	25	14
SNT 6 × 1/4		1/4		28	17
SNT 6 × 3/8		3/8		30	21
SNT 6 × 1/2		1/2		35	26
SNT 8 × 1/8	8	1/8	Rc NPT	27	17
SNT 8 × 1/4		1/4		30	
SNT 8 × 3/8		3/8		32	21
SNT 8 × 1/2		1/2		37	26
SNT 10 × 1/8	10	1/8	Rc NPT	27	17
SNT 10 × 1/4		1/4		30	
SNT 10 × 3/8		3/8		32	21
SNT 10 × 1/2		1/2		37	26
SNT 12 × 1/4	12	1/4	Rc NPT	32	21
SNT 12 × 3/8		3/8		34	
SNT 12 × 1/2		1/2		39	26
SNT 16 × 1/2	16	1/2	Rc NPT	44	29
SNT 18 × 1/2	18	1/2	Rc NPT	44	
SNT 18 × 3/4		3/4		46	
SNT 1/4 × 1/8	6.35 (1/4")	1/8	Rc NPT	25	14
SNT 1/4 × 1/4		1/4		28	17
SNT 1/4 × 3/8		3/8		30	21
SNT 1/4 × 1/2		1/2		35	26
SNT 3/8 × 1/8	9.52 (3/8")	1/8	Rc NPT	27	17
SNT 3/8 × 1/4		1/4		30	
SNT 3/8 × 3/8		3/8		32	21
SNT 3/8 × 1/2		1/2		37	26
SNT 1/2 × 1/4	12.7 (1/2")	1/4	Rc NPT	32	21
SNT 1/2 × 3/8		3/8		34	
SNT 1/2 × 1/2		1/2		39	26

LMT-TYPE

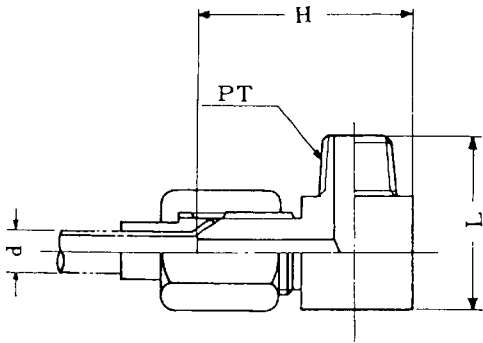
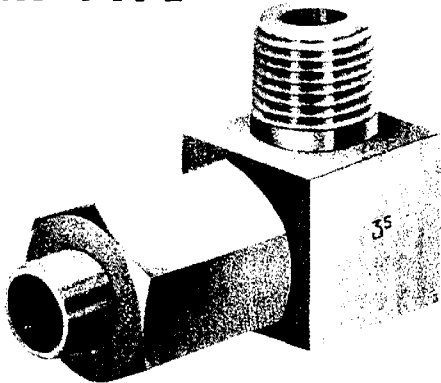

単位/mm
Dimension in mm

型式 Type	使用銅管外径 Tube O.D	管用ネジ Pipe thread		L	H
	d	PT			
LMT 6 × 1/8	6	1/8	R NPT	22	24
LMT 6 × 1/4				27	26
LMT 6 × 3/8				33	31
LMT 6 × 1/2				41	35
LMT 8 × 1/8	8	1/8	R NPT	27	31
LMT 8 × 1/4				30	
LMT 8 × 3/8				33	33
LMT 8 × 1/2				41	
LMT 10 × 1/8	10	1/8	R NPT	27	31
LMT 10 × 1/4				30	
LMT 10 × 3/8				33	33
LMT 10 × 1/2				41	
LMT 12 × 1/4	12	1/4	R NPT	34	37
LMT 12 × 3/8				35	
LMT 12 × 1/2				41	39
LMT 16 × 1/2	16	1/2	R NPT	45	48
LMT 18 × 1/2	18	1/2	R NPT	47	50
LMT 18 × 3/4				39	
LMT 1/4 × 1/8	6.35 (1/4")	1/8	R NPT	22	24
LMT 1/4 × 1/4				27	26
LMT 1/4 × 3/8				33	31
LMT 1/4 × 1/2				41	35
LMT 3/8 × 1/8	9.52 (3/8")	1/8	R NPT	27	31
LMT 3/8 × 1/4				30	
LMT 3/8 × 3/8				33	33
LMT 3/8 × 1/2				41	
LMT 1/2 × 1/4	12.7 (1/2")	1/4	R NPT	34	37
LMT 1/2 × 3/8				35	
LMT 1/2 × 1/2				41	39

LNT-TYPE

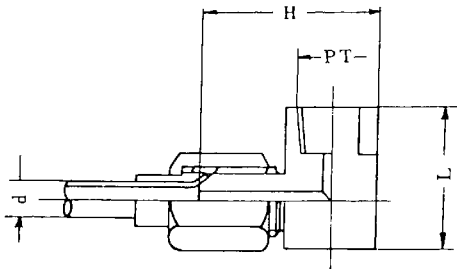

単位/mm
Dimension in mm

型式 Type	使用銅管外径 Tube O.D	管用ネジ Pipe thread		L	H
	d	PT			
LNT 6 × 1/8	6	1/8	Rc NPT	20	26
LNT 6 × 1/4				25	29
LNT 6 × 3/8				30	33
LNT 6 × 1/2				37	38
LNT 8 × 1/4	8	1/4	Rc NPT	25	31
LNT 8 × 3/8				30	35
LNT 8 × 1/2				37	40
LNT 10 × 1/4	10	1/4	Rc NPT	28	31
LNT 10 × 3/8				30	35
LNT 10 × 1/2				37	40
LNT 12 × 1/4	12	1/4	Rc NPT	30	37
LNT 12 × 3/8				37	42
LNT 12 × 1/2				37	42
LNT 16 × 1/2	16	1/2	Rc NPT	38	48
LNT 18 × 1/2	18	1/2	Rc NPT	44	53
LNT 18 × 3/4				34	
LNT 1/4 × 1/8	6.35 (1/4")	1/8	Rc NPT	20	26
LNT 1/4 × 1/4				25	29
LNT 1/4 × 3/8				30	33
LNT 1/4 × 1/2				37	38
LNT 3/8 × 1/4	9.52 (3/8")	1/4	Rc NPT	28	31
LNT 3/8 × 3/8				30	35
LNT 3/8 × 1/2				37	40
LNT 1/2 × 1/4	12.7 (1/2")	1/4	Rc NPT	30	37
LNT 1/2 × 3/8				37	42
LNT 1/2 × 1/2				37	42

LT-TYPE

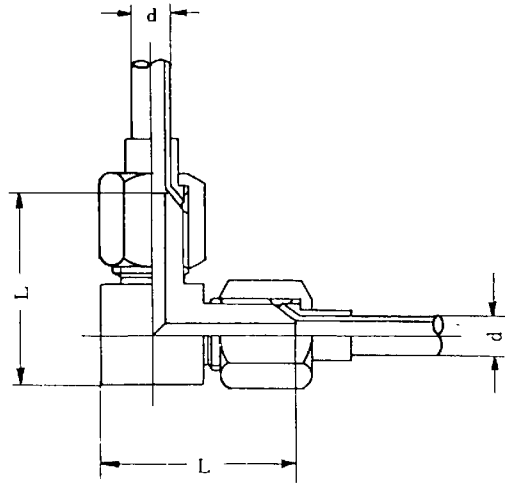

単位/mm
Dimension in mm

型 式 Type	使用銅管外径 Tube O.D	L
	d	
L T 6	6	25
L T 8	8	32
L T 10	10	
L T 12	12	38
L T 15	15	41
L T 16	16	48
L T 18	18	51
L T 20	20	
L T 22	22	54
L T 25	25	57
L T ¼	6.35 (¼")	25
L T ⅜	9.52 (⅜")	32
L T ½	12.7 (½")	38
L T ¾	19.05 (¾")	51
L T 1	25.4 (1")	57

TT-TYPE

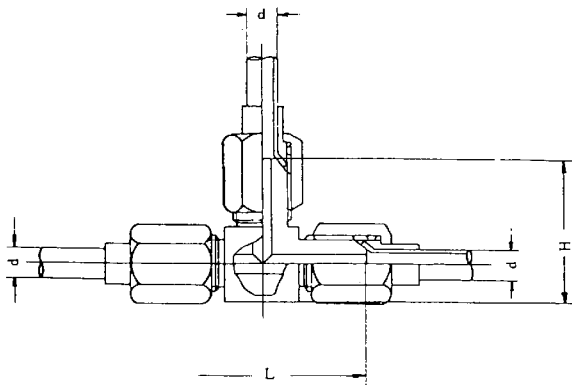
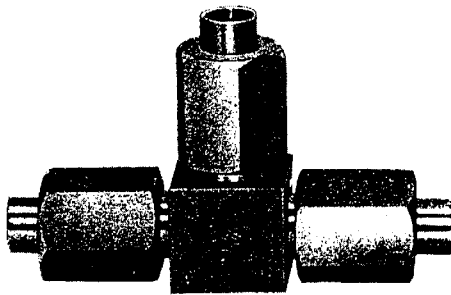

単位/mm
Dimension in mm

型 式 Type	使用銅管外径 Tube O.D	L	H
	d		
T T 6	6	38	25
T T 8	8	47	32
T T 10	10		
T T 12	12	55	38
T T 15	15	59	41
T T 16	16	69	48
T T 18	18	73	51
T T 20	20		
T T 22	22	76	54
T T 25	25	79	57
T T ¼	6.35 (¼")	38	25
T T ⅜	9.52 (⅜")	47	32
T T ½	12.7 (½")	55	38
T T ¾	19.05 (¾")	73	51
T T 1	25.4 (1")	79	57

TMTT-TYPE

単位/mm
Dimension in mm

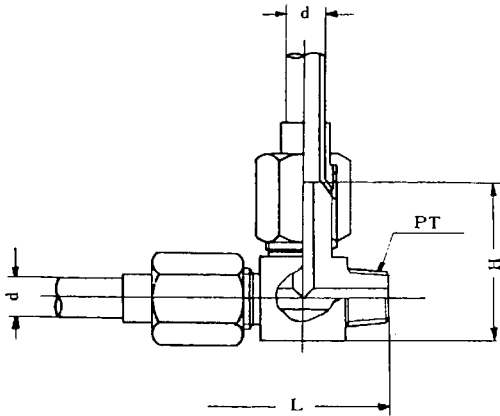

型式 Type	使用銅管外径 Tube O.D	管用ネジ Pipe thread		L	H
	d	PT			
TMTT 6 × 1/8	6	R NPT	1/8	35	25
TMTT 6 × 1/4			1/4	40	27
TMTT 6 × 3/8			3/8	46	32
TMTT 6 × 1/2			1/2	54	36
TMTT 8 × 1/4	8	R NPT	1/4	42	32
TMTT 8 × 3/8			3/8	48	34
TMTT 8 × 1/2			1/2	56	38
TMTT 10 × 1/4	10	R NPT	1/4	42	32
TMTT 10 × 3/8			3/8	48	34
TMTT 10 × 1/2			1/2	56	38
TMTT 12 × 1/4	12	R NPT	1/4	51	38
TMTT 12 × 3/8			3/8	52	
TMTT 12 × 1/2			1/2	58	40
TMTT 1/4 × 1/8	6.35 (1/4")	R NPT	1/8	35	25
TMTT 1/4 × 1/4			1/4	40	27
TMTT 1/4 × 3/8			3/8	46	32
TMTT 1/4 × 1/2			1/2	54	36
TMTT 3/8 × 1/4	9.52 (3/8")	R NPT	1/4	42	32
TMTT 3/8 × 3/8			3/8	48	34
TMTT 3/8 × 1/2			1/2	56	38
TMTT 1/2 × 1/4	12.7 (1/2")	R NPT	1/4	51	38
TMTT 1/2 × 3/8			3/8	52	
TMTT 1/2 × 1/2			1/2	58	40

TNTT-TYPE

単位/mm
Dimension in mm

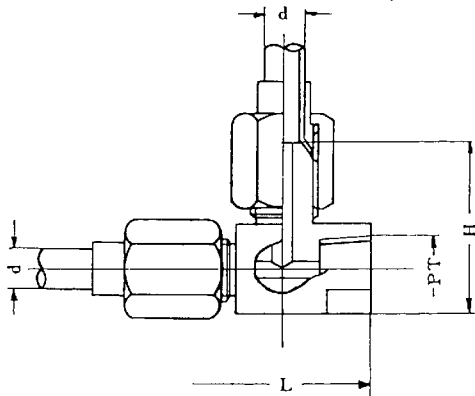

型式 Type	使用銅管外径 Tube O.D	管用ネジ Pipe thread		L	H
	d	PT			
TNTT 6 × 1/8	6	Rc NPT	1/8	33	27
TNTT 6 × 1/4			1/4	38	30
TNTT 6 × 3/8			3/8	43	34
TNTT 6 × 1/2			1/2	50	39
TNTT 8 × 1/4	8	Rc NPT	1/4	40	32
TNTT 8 × 3/8			3/8	45	36
TNTT 8 × 1/2			1/2	52	41
TNTT 10 × 1/4	10	Rc NPT	1/4	43	32
TNTT 10 × 3/8			3/8	45	36
TNTT 10 × 1/2			1/2	52	41
TNTT 12 × 1/4	12	Rc NPT	1/4	47	38
TNTT 12 × 3/8			3/8	47	38
TNTT 12 × 1/2			1/2	54	43
TNTT 1/4 × 1/8	6.35 (1/4")	Rc NPT	1/8	33	27
TNTT 1/4 × 1/4			1/4	38	30
TNTT 1/4 × 3/8			3/8	43	34
TNTT 1/4 × 1/2			1/2	50	39
TNTT 3/8 × 1/4	9.52 (3/8")	Rc NPT	1/4	43	32
TNTT 3/8 × 3/8			3/8	45	36
TNTT 3/8 × 1/2			1/2	52	41
TNTT 1/2 × 1/4	12.7 (1/2")	Rc NPT	1/4	47	38
TNTT 1/2 × 3/8			3/8	47	38
TNTT 1/2 × 1/2			1/2	54	43

TTTN-TYPE

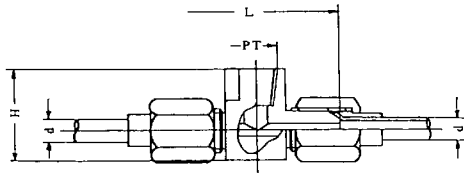
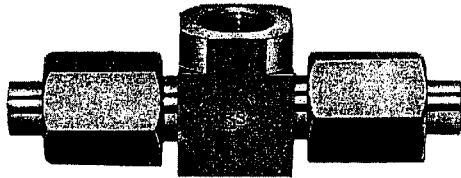

単位/mm
Dimension in mm

型式 Type	使用銅管外径 Tube O.D.		管用ネジ Pipe thread		L	H
	d		PT			
TTTN 6 × 1/8	6		1/8	Rc NPT	38	20
TTTN 6 × 1/4			1/4		41	25
TTTN 6 × 3/8			3/8		45	30
TTTN 6 × 1/2			1/2		50	37
TTTN 8 × 1/4	8		1/4	Rc NPT	45	25
TTTN 8 × 3/8			3/8		49	30
TTTN 8 × 1/2			1/2		54	37
TTTN 10 × 1/4	10		1/4	Rc NPT	45	28
TTTN 10 × 3/8			3/8		49	30
TTTN 10 × 1/2			1/2		54	37
TTTN 12 × 1/4	12		1/4	Rc NPT	53	30
TTTN 12 × 3/8			3/8		53	30
TTTN 12 × 1/2			1/2		58	37
TTTN 1/4 × 1/8	6.35 (1/4")		1/8	Rc NPT	38	20
TTTN 1/4 × 1/4			1/4		41	25
TTTN 1/4 × 3/8			3/8		45	30
TTTN 1/4 × 1/2			1/2		50	37
TTTN 3/8 × 1/4	9.52 (3/8")		1/4	Rc NPT	45	28
TTTN 3/8 × 3/8			3/8		49	30
TTTN 3/8 × 1/2			1/2		54	37
TTTN 1/2 × 1/4	12.7 (1/2")		1/4	Rc NPT	53	30
TTTN 1/2 × 3/8			3/8		53	30
TTTN 1/2 × 1/2			1/2		58	37

TMNT-TYPE

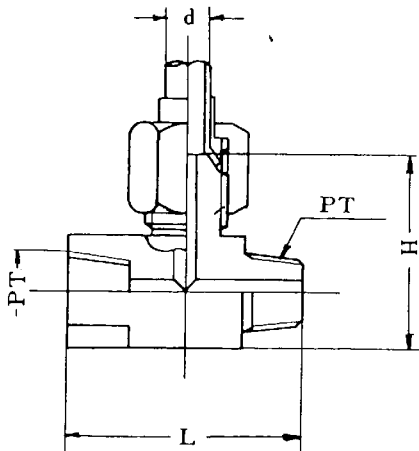

単位/mm
Dimension in mm

型式 Type	使用銅管外径 Tube O.D.		管用ネジ Pipe thread		L	H
	d		PT			
TMNT 6 × 1/8	6		1/8	R.Rc NPT	30	26
TMNT 6 × 1/4			1/4		38	29
TMNT 6 × 3/8			3/8		44	33
TMNT 6 × 1/2			1/2		55	38
TMNT 8 × 1/4	8		1/4	R.Rc NPT	38	31
TMNT 8 × 3/8			3/8		44	35
TMNT 8 × 1/2			1/2		55	40
TMNT 10 × 1/4	10		1/4	R.Rc NPT	41	31
TMNT 10 × 3/8			3/8		44	35
TMNT 10 × 1/2			1/2		55	40
TMNT 12 × 1/4	12		1/4	R.Rc NPT	43	37
TMNT 12 × 3/8			3/8		44	
TMNT 12 × 1/2			1/2		55	42
TMNT 1/4 × 1/8	6.35 (1/4")		1/8	R.Rc NPT	30	26
TMNT 1/4 × 1/4			1/4		38	29
TMNT 1/4 × 3/8			3/8		44	33
TMNT 1/4 × 1/2			1/2		55	38
TMNT 3/8 × 1/4	9.52 (3/8")		1/4	R.Rc NPT	41	31
TMNT 3/8 × 3/8			3/8		44	35
TMNT 3/8 × 1/2			1/2		55	40
TMNT 1/2 × 1/4	12.7 (1/2")		1/4	R.Rc NPT	43	37
TMNT 1/2 × 3/8			3/8		44	
TMNT 1/2 × 1/2			1/2		55	42

TTTV-TYPE

単位/mm
Dimension in mm

型式 Type	使用銅管外径 Tube O.D	L	A [□]	H	ℓ	D
	d					
TTTV 6	6	38	14	34	2	25
TTTV 8	8	45	17	46	3	32
TTTV 10	10	47	19			36
TTTV 12	12	55	23	50	4	42
TTTV ¼	6.35 (¼")	38	14	34	2	25
TTTV ⅜	9.52 (⅜")	47	19	46	3	36
TTTV ½	12.7 (½")	55	23	50	4	42

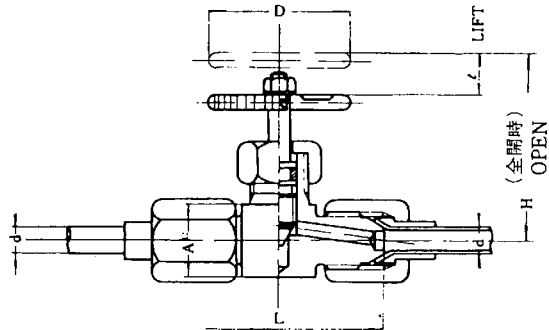
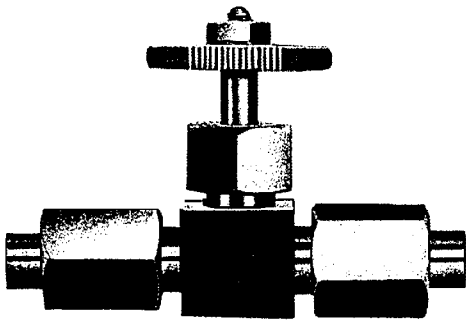

TMTV-TYPE

単位/mm
Dimension in mm

型式 Type	使用銅管 管 外径 Tube O.D	管 用 管 ネ シ Pipe thread		L	A [□]	H	ℓ	D
	d	PT						
TMTV 6 × ⅛	6	⅛	R NPT	36	14	34	2	25
TMTV 6 × ¼		¼		39				
TMTV 8 × ¼	8	¼	R NPT	44	17	46	3	32
TMTV 10 × ¼	10	¼		46				
TMTV 10 × ⅜		⅜	47					
TMTV 10 × ½	½	55						
TMTV 12 × ¼	12	¼	R NPT	52	23	50	4	42
TMTV 12 × ⅜		⅜		53				
TMTV 12 × ½	½	57						
TMTV ¼ × ⅛	6.35 (¼")	⅛	R NPT	36	14	34	2	25
TMTV ¼ × ¼		¼		39				
TMTV ⅜ × ¼	9.52 (⅜")	¼	R NPT	46	19	46	3	36
TMTV ⅜ × ⅜		⅜		47				
TMTV ⅜ × ½	½	55						
TMTV ½ × ¼	12.7 (½")	¼	R NPT	52	23	50	4	42
TMTV ½ × ⅜		⅜		53				
TMTV ½ × ½	½	57						

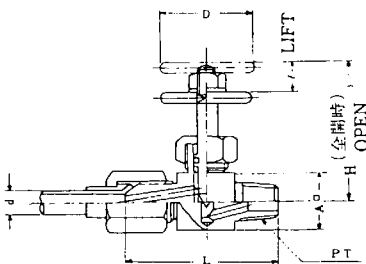
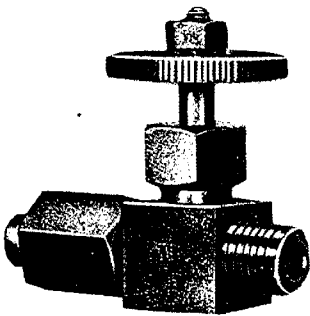

TNTV-TYPE

単位/mm
Dimension in mm

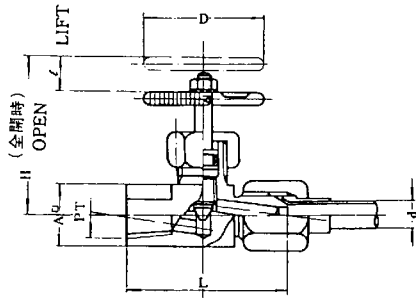

型式 Type	使用銅管 Tube O.D		管用ネジ Pipe thread		L	A [□]	H	ℓ	D
	d		P T						
TNTV 6 × 1/8	6	6	1/8	Rc NPT	36	14	34	2	25
TNTV 6 × 1/4			1/4		41	17			
TNTV 8 × 1/4			8		1/4	45			
TNTV 10 × 1/4	10	10	1/4	Rc NPT	46	19	46	3	36
TNTV 10 × 3/8			3/8		49	21			
TNTV 10 × 1/2			1/2		58	26			
TNTV 12 × 1/4	12	12	1/4	Rc NPT	53	23	50	4	42
TNTV 12 × 3/8			3/8		53	23			
TNTV 12 × 1/2			1/2		60	26			
TNTV 1/4 × 1/8	6.35 (1/4")	6.35	1/8	Rc NPT	36	14	34	2	25
TNTV 1/4 × 1/4			1/4		41	17			
TNTV 3/8 × 1/4	9.52 (3/8")	9.52	1/4	Rc NPT	46	19	46	3	36
TNTV 3/8 × 3/8			3/8		49	21			
TNTV 3/8 × 1/2			1/2		58	26			
TNTV 1/2 × 1/4	12.7 (1/2")	12.7	1/4	Rc NPT	53	23	50	4	42
TNTV 1/2 × 3/8			3/8		53	23			
TNTV 1/2 × 1/2			1/2		60	26			

TTVM-TYPE

単位/mm
Dimension in mm

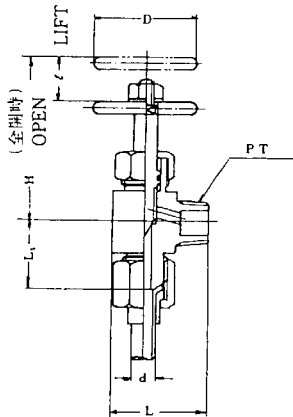

型式 Type	使用銅管 Tube O.D		管用ネジ Pipe thread		L	L ₁	H	ℓ	D
	d		P T						
TTVM 6 × 1/8	6	6	1/8	R NPT	24	19	34	2	25
TTVM 6 × 1/4			1/4		27				
TTVM 8 × 1/4			8		1/4				
TTVM 10 × 1/4	10	10	1/4	R NPT	32	23.5	46	3	36
TTVM 10 × 3/8			3/8		33				
TTVM 10 × 1/2			1/2		41				
TTVM 12 × 1/4	12	12	1/4	R NPT	36	27.5	50	4	42
TTVM 12 × 3/8			3/8		37				
TTVM 12 × 1/2			1/2		41				
TTVM 1/4 × 1/8	6.35 (1/4")	6.35	1/8	R NPT	24	19	34	2	25
TTVM 1/4 × 1/4			1/4		27				
TTVM 3/8 × 1/4	9.52 (3/8")	9.52	1/4	R NPT	32	23.5	46	3	36
TTVM 3/8 × 3/8			3/8		33				
TTVM 3/8 × 1/2			1/2		41				
TTVM 1/2 × 1/4	12.7 (1/2")	12.7	1/4	R NPT	36	27.5	50	4	42
TTVM 1/2 × 3/8			3/8		37				
TTVM 1/2 × 1/2			1/2		41				

TMVT-TYPE

単位/mm
Dimension in mm

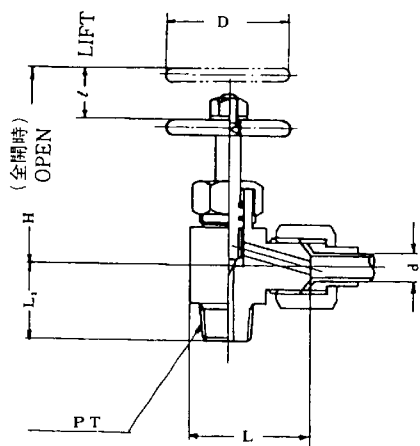

型式 Type	使用銅管 Tube O.D	管用ネジ Pipe thread	L	L ₁	H	ℓ	D
	d	PT					
TMVT 6 × 1/8	6	1/8	26	17	34	2	25
TMVT 6 × 1/4		1/4					
TMVT 8 × 1/4	8	1/4	31	21.5	46	3	32
TMVT 10 × 1/4		1/4					
TMVT 10 × 3/8	10	3/8	33	22.5	46	3	36
TMVT 10 × 1/2		1/2					
TMVT 12 × 1/4	12	1/4	39	24.5	50	4	42
TMVT 12 × 3/8		3/8					
TMVT 12 × 1/2	1/2	1/2	37	29.5			
TMVT 1/4 × 1/8	6.35 (1/4")	1/8	26	17	34	2	25
TMVT 1/4 × 1/4		1/4		20			
TMVT 3/8 × 1/4	9.52 (3/8")	1/4	33	22.5	46	3	36
TMVT 3/8 × 3/8		3/8		23.5			
TMVT 3/8 × 1/2	1/2	1/2	37	29.5			
TMVT 1/2 × 1/4	12.7 (1/2")	1/4	39	24.5	50	4	42
TMVT 1/2 × 3/8		3/8		25.5			
TMVT 1/2 × 1/2	1/2	1/2	39	29.5			

TNNV-TYPE

単位/mm
Dimension in mm

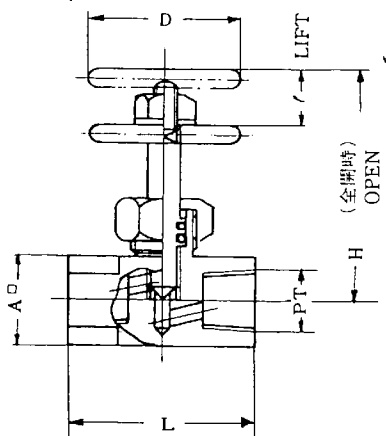

型式 Type	管用ネジ Pipe thread		L	A [□]	H	ℓ	D
	PT						
TNNV 1/8	1/8	Re NPT	35	14	34	2	25
TNNV 1/4	1/4	Re NPT	45	17	46	3	32
TNNV 3/8	3/8	Re NPT	50	21			
TNNV 1/2	1/2	Re NPT	65	26	50	4	42